

GN 923.40



GN 924.40



Disc handwheel Ø 100

for linear actuators Ø 40

SPECIFICATION

Type

- Type **R**: with revolving handle

Bore code

- Version **K**: with keyway

Aluminium die casting

Hub machined

Rim turned

plastic coated

black, RAL 9005, textured finish **SW**

Concentric runout and axial runout deviation of the rim < 0.4

Revolving handles GN 798.2 (see page 578)

Plastic, Technopolymer

black, matt

INFORMATION

- Linear actuators GN 291 (see page 1912)

- Linear actuators GN 291.1 (see page 1930)

Spoked handwheel Ø 125

for linear actuators Ø 40

SPECIFICATION

Type

- Type **R**: with revolving handle

Bore code

- Version **K**: with keyway

Aluminium die casting

Hub machined

Rim turned

plastic coated

black, RAL 9005, textured finish **SW**

Concentric runout and axial runout deviation of the rim < 0.4

Revolving handles GN 798.2 (see page 578)

Plastic, Technopolymer

black, matt

INFORMATION

- Linear actuators GN 291 (see page 1912)

- Linear actuators GN 291.1 (see page 1930)

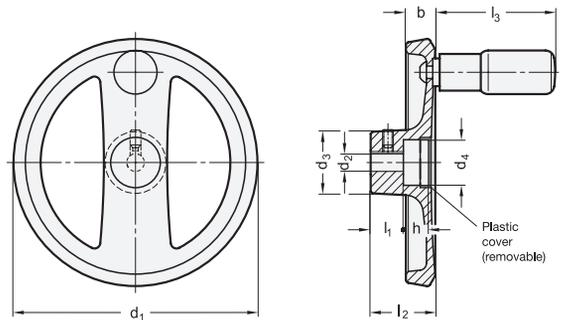
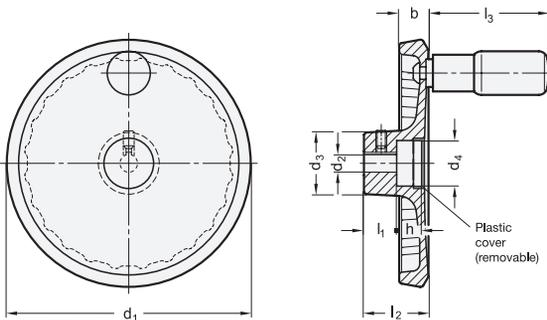

GN 923.40

Description	d1	d2	d3	d4	b	h	l1	l2	l3 ≈	Ø Handle GN 798	⚖
GN 923.40-100-K12-R	100	12	28	22	14	9.5	17	30	61.5	18	180

GN 924.40

Description	d1	d2	d3	d4	b	h	l1	l2	l3 ≈	Ø Handle GN 798	⚖
GN 924.40-125-K12-R	125	12	31	23	15	11	18	33.5	61.5	22	340